

DORLE CONTROLS

# Vehicle Control Systems for Everybody

*Learn by doing...*

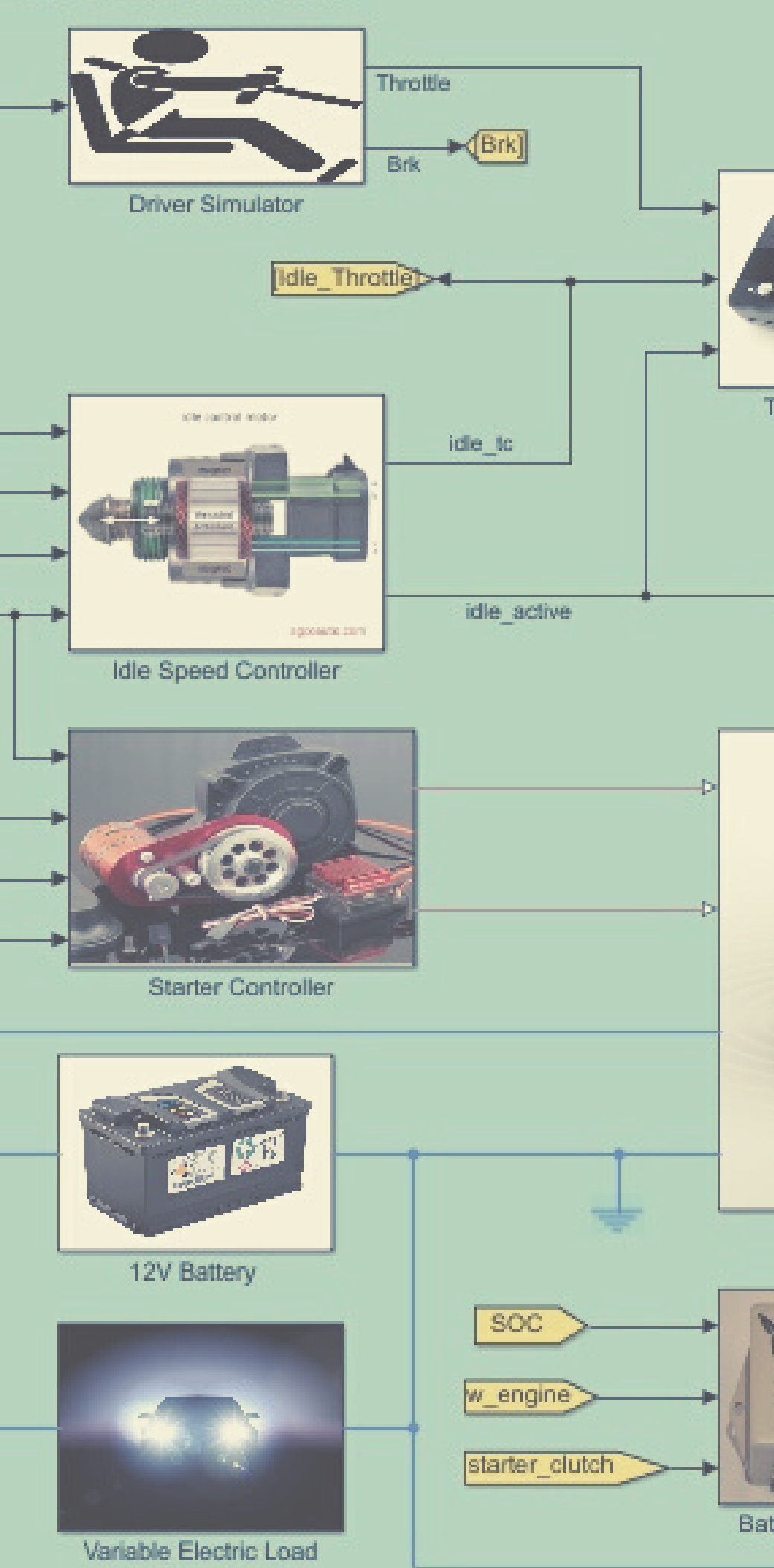



# Topic Outline

Vehicle Control Systems for Everybody or VCSE is 200 hours of task-based learning program for those interested in learning the fundamentals of system modelling, simulation, controls and analysis. The program starts on Jan18 and ends on Feb18.

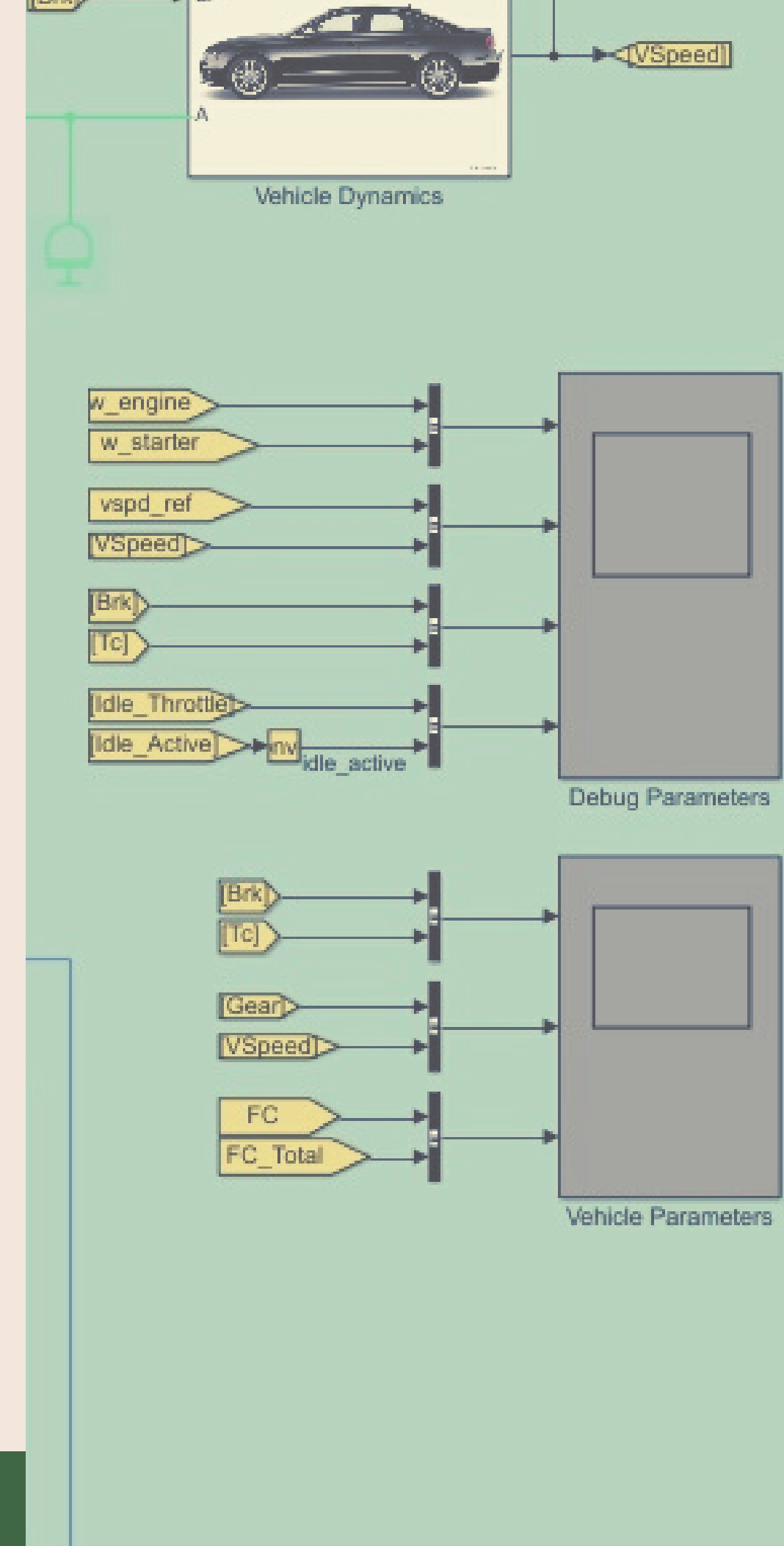

A photograph of three men in a control room, looking at a large screen and a laptop. The image is overlaid with a semi-transparent green filter. The text is positioned on the left side of the image.

WORK WITH OUR  
ENGINEERS

---

LEARN BY  
HELPING US  
SOLVE A  
PROBLEM

---

No classroom instructions

---

VCSE is a live research based program unlike typical classroom teaching programs. It provides you with a first hand experience of how a controls software engineering job is done in a company.

It's a mix of internship and a learning platform where you get to work with a live team and a mentor on a project that counts.



# WORK ON THE LATEST AREAS

## Powertrain

Design and development of feature software, controls, calibration, testing, research and analysis of engine, motor, battery systems.

## Transmission

Development of controls and software for a variety of transmission control systems including CVT, DCT, PGT, AMT, Manual and AT

## Autonomy

We are developing model-based controls software for ADAS features, generating test scenarios, verifying and validating the software in CV, SLAM, OD, SF areas.

## Integration

Integration of software and hardware, supervisory controls, interface management system and application layer generation and testing.

# What you'll work on?

## TENTATIVE TOPICS

---



MATLAB  
SIMULINK  
practice

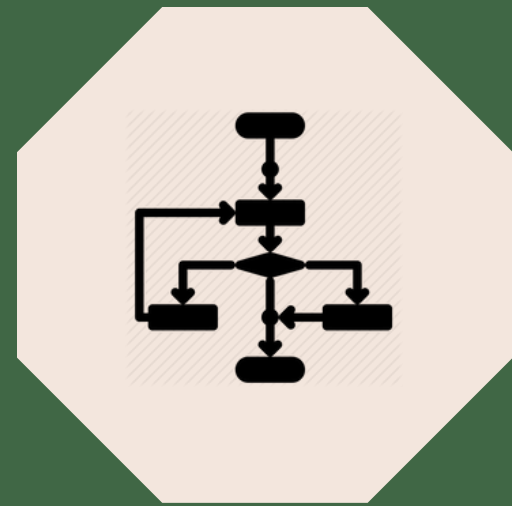

Feedback  
systems  
implementation



Modeling  
automotive  
dynamics



Design an  
intelligent  
system



Technical report  
& presentation  
in SAE format

# LEARN HANDS ON

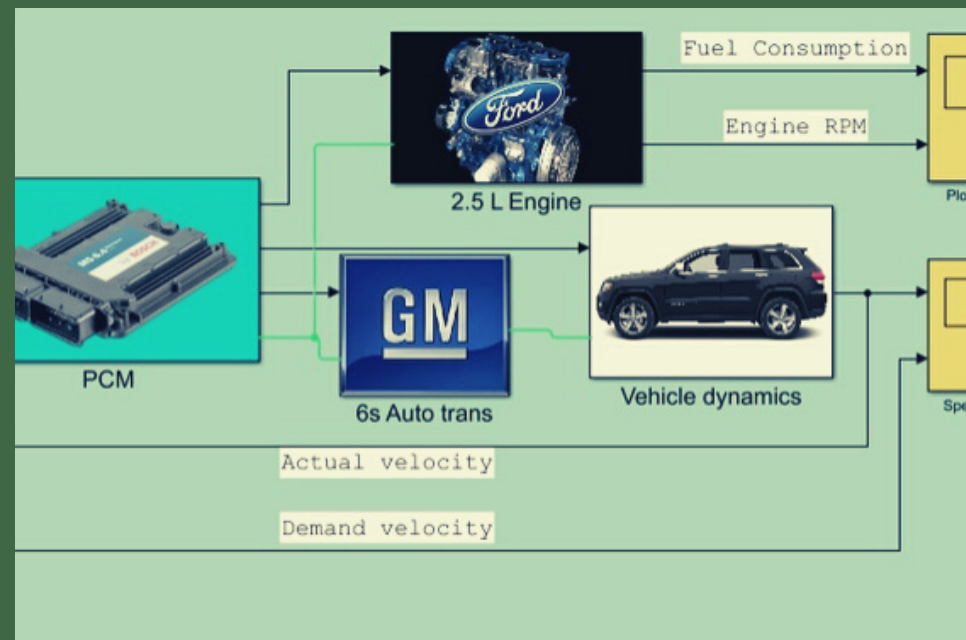

MODEL



CODE



TEST



# YOU WILL WORK WITH

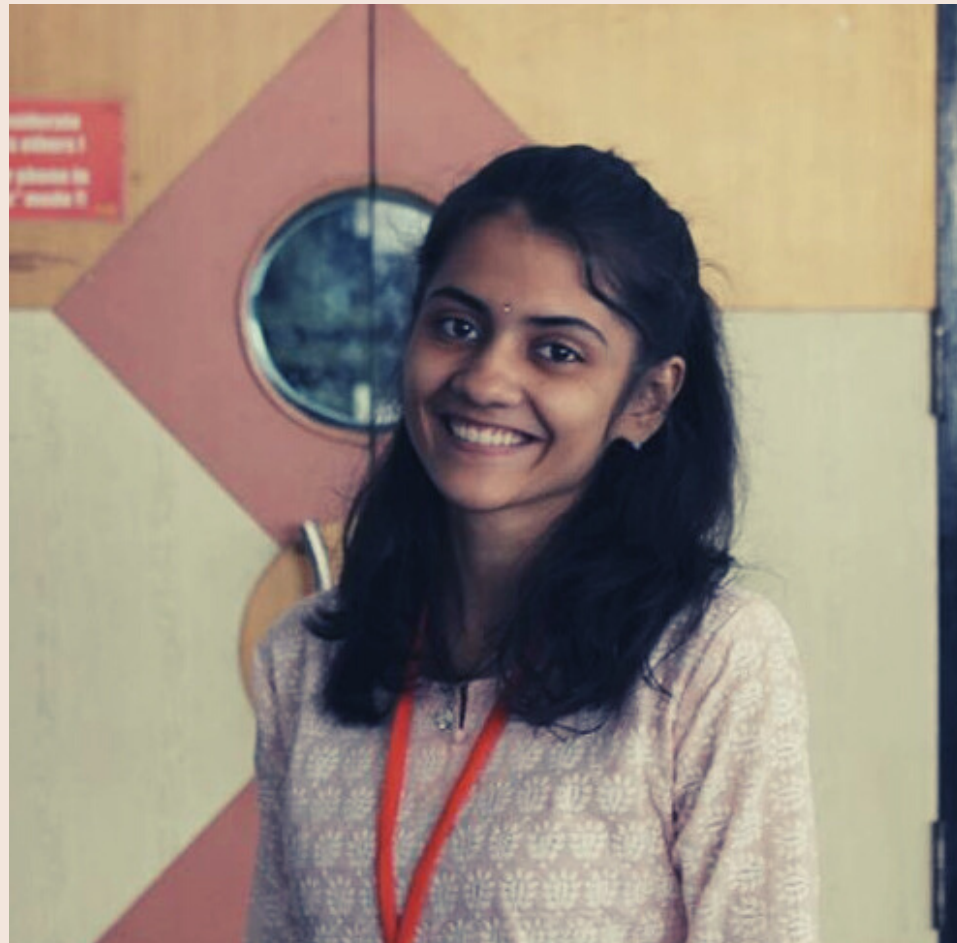

Priyanka D  
e-Powertrain Controls



Mayur W  
ADAS software



Kantesh B  
Vehicle integration



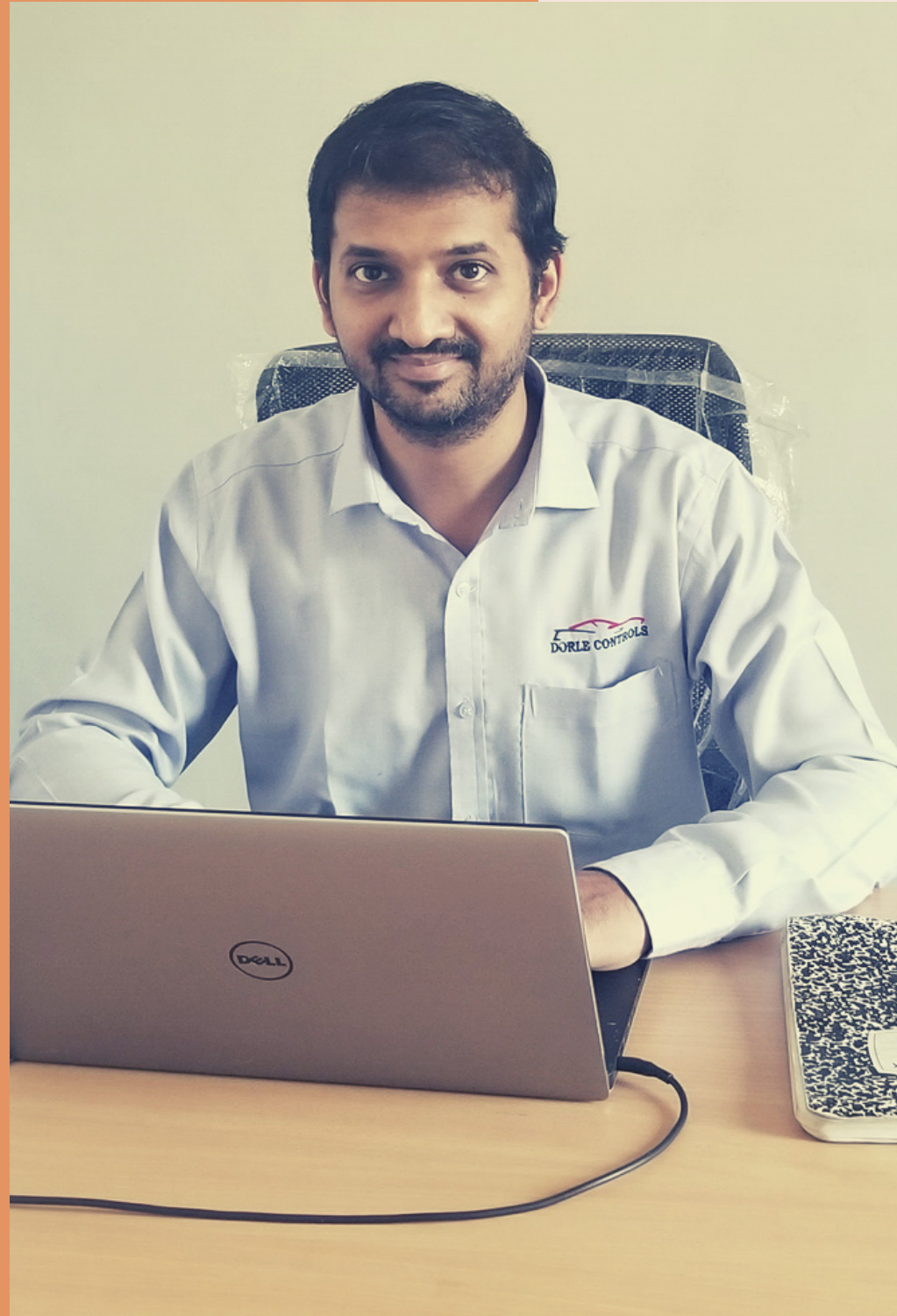

# Ani Dorle

## MBD CONTROLS SPECIALIST

---

### Professional Background

Ani has been solving automotive engineering problems since 2007 in the areas of powertrain and since 2018 in ADAS

### Skills

His primary work involves modeling, controls, coding, scripting, algorithm design, requirements, robustness, architecture, MIL/SIL/in vehicle testing, CAN comstack, vehicle system integration co-simulation.

# Take the right foot forward

---

## Solve real life problems

You'd work on tasks we are trying to solve and learn in the process. It's a unique opportunity to showcase your problem solving skills

## Get certified

you will be issued a certificate of participation / completion / excellence based on your performance.

## Start your journey in controls software

The best way to get started is by getting something done. There is overwhelming amounts of literature out there but if you didn't implement you hardly learnt.

# ALL YOU NEED IS

1

## HOME OFFICE

Presentations are communication tools that can be demonstrations, and more.

2

## COMPUTER

Presentations are communication tools that can be demonstrations, and more.

3

## ZOOM

Presentations are communication tools that can be demonstrations, and more.

4

## SIMULINK

Presentations are communication tools that can be demonstrations, and more.



# Enrollment Contact

SEND OUT AN EMAIL TO



Mayuri P

[mayuri@dorleco.com](mailto:mayuri@dorleco.com)



The background of the image is a collage of various automotive parts. On the left, there is a detailed view of a car engine with a black plastic cover and various hoses. In the center, a car chassis is shown with a silver alloy wheel. On the right, another engine is visible, possibly from a different vehicle, with a black plastic cover and a silver alloy wheel. The entire collage is set against a light green background with a dark green horizontal bar at the bottom.

---

**Thank you.**

Have a great day!